

**Technical data sheet 716K**

Specification Standing table 60x60 cm, three legged

Dimensions in mm

Total: H: 1085  
 W: 600  
 D: 600

Total: H: 1325  
 W (no ArmR): 635  
 D: 610

Packaging data Weight: kg 13  
 Volume: m³ 0,64

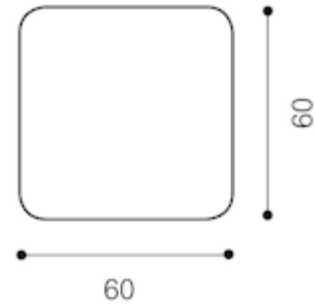

**Basic equipment**

**Benefit**

Table top Squared 60 x 60 cm. MDF, 25 mm surface HPL, black.

Table edge ABS, chamfer edge. Same colour as table top surface.

Base/Metal parts Aluminium casting, 3-star, powder coated black. Vertical, cylindrical tubular steel Ø 50x1.5 mm with steel support plate.

High level of satiability, longevity

Glides Hard glides for soft floors.

High stability.

Materials All materials are segregated and recyclable.

Environmentally friendly, help to protect resources.

Certifications Quality management system DIN EN ISO 9001:2008, VO (EG) No. 1221/2009 (EMAS), Environmental management system DIN EN ISO 14001:2009, OHSAS, EcoVadis gold, Commitment to sustainability. Blue Angel, Bifma e3 level Platin.

High-quality product.

Warranty and Return 10 years warranty. Complete return and recycling guarantee.

Exchange of parts, free of charge within the guaranteed period.

**Technical data sheet 716K**

Specification Standing table 60x60 cm, three legged

Dimensions in mm

Total:	H:	1085
	W:	600
	D:	600

Total:	H:	1325
	W (no ArmR):	635
	D:	610

Packaging data	Weight:	kg	13
	Volume:	m³	0,64

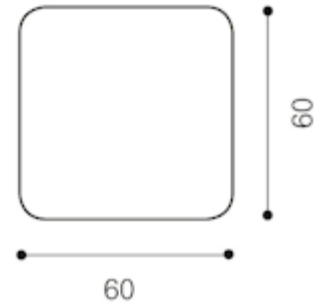

Options		Benefit
Top surface	HPL white, wood veneer in oak or American walnut.	Individual design.
Metal parts/Tubular steel	Aluminium, casting powder coated brilliant silver, white or brushed.	Design options.
Flip-top	Flip-top table (to nest 10 tables of about 1.76 m)	Saves space, as they can be nested
Glides	Soft glides for hard floors.	High stability.

**Technical data sheet 717K**

Specification Standing table 70x70 cm, three legged

Dimensions in mm

Total:	H:	1085
	W:	700
	D:	700

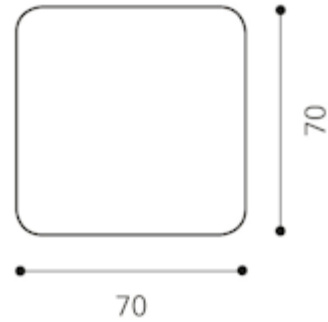

Packaging data	Weight:	kg	14
	Volume:	m³	0,7

**Basic equipment**

**Benefit**

Table top	Squared 70 x 70 cm. MDF, 25 mm surface HPL, black.	
Table edge	ABS, chamfer edge. Same colour as table top surface.	
Base/Metal parts	Aluminium casting, 3-star, powder coated black. Vertical, cylindrical tubular steel Ø 50x1.5 mm with steel support plate.	High level of satiability, longevity
Glides	Hard glides for soft floors.	High stability.
Materials	All materials are segregated and recyclable.	Environmentally friendly, help to protect resources.
Certifications	Quality management system DIN EN ISO 9001:2008, VO (EG) No. 1221/2009 (EMAS), Environmental management system DIN EN ISO 14001:2009, OHSAS, EcoVadis gold, Commitment to sustainability. Blue Angel, Bifma e3 level Platin.	High-quality product.
Warranty and Return	10 years warranty. Complete return and recycling guarantee.	Exchange of parts, free of charge within the guaranteed period.

**Technical data sheet 717K**

Specification Standing table 70x70 cm, three legged

Dimensions in mm

Total:	H:	1085
	W:	700
	D:	700

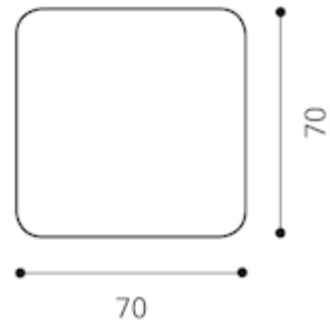

Packaging data	Weight:	kg	14
	Volume:	m³	0,7

Options		Benefit
Top surface	HPL white, wood veneer in oak or American walnut.	Individual design.
Metal parts/Tubular steel	Aluminium, casting powder coated brilliant silver, white or brushed.	Design options.
Flip-top	Flip-top table (to nest 10 tables of about 1.76 m)	Saves space, as they can be nested
Glides	Soft glides for hard floors.	High stability.